

3-D Numerical Modelling of *Cakar Ayam* System to Maximize It's Stability Performance

Agus Sulaeman¹, Sajiharjo Marto Suro², Salihin bin Jalali^{3*}

¹Universitas Komputer Indonesia, UNIKOM, Bandung, Indonesia

²Universiti Tun Hussein Onn Malaysia, Parit Raja, Batu Pahat, Johor Darul Ta'zim, Malaysia

³Universiti Tun Hussein Onn Malaysia, Parit Raja, Batu Pahat, Johor Darul Ta'zim, Malaysia

Email: agus@uthm.edu.my

Abstract: This paper presents an analysis of Cakar Ayam system using the finite element method. The basic concept of the Cakar Ayam system considers the passive-soil pressure creating a stiff condition of slab-pipe system. This means that the thin concrete slab floats on the supporting soil and the pipes serve as stiffeners slab concrete, stay vertical due to the passive-soil pressure. In this study, the simulation was done to the stiffness ratio of 0.02 to 1.2 under soil friction angle 20°, bearing capacity and displacement were recorded for each pairs then plotted in the graph. The study was intended to illustrate the basic mechanism of the Cakar Ayam system. Two cases have been considered for the parametric studies. The parameters investigated are thickness of slab and diameter of pipes. It is shown that such a Cakar Ayam system improves the behaviour of the raft foundation. It is also found that all the parameters used in the parametric studies influence the behaviour of the Cakar Ayam system.

Keywords: Cakar Ayam system, finite element, bearing capacity, displacement.

1. Introduction

Cakar Ayam (CA) system invented by Sedijatmo (1961) is intended to overcome the problem of foundation structures on soft soil. Several construction projects in soft soil areas have been improved using Cakar Ayam system [1].

The Cakar Ayam system consists of a reinforced concrete slab of 8 to 20 cm thick and a number of reinforced concrete pipes.

The pipe has a diameter of 0.80 to 1.60 m, length of 1.50 to 3.50 m and thickness of 0.08 to 0.15 m; the spacing between pipes is between 2.00 and 2.50 m [2], as shown in Fig. 1. The pipes are filled and surrounded by in-situ soil.

The basic concept of the Cakar Ayam system considers the passive-soil pressure creating a flexible condition of slab-pipe system. This means that the thin concrete slab floats on the supporting soil and the pipes serve as stiffeners to slab concrete, and will stay vertical due to the passive-soil pressure [3], as shown in Fig. 2.

It is believed that the performance behaviour of high capacity of Cakar Ayam system was not explained clearly, the inventor merely revealed passive pressure to the public. According to the concepts of geotechnics in evaluating of Cakar Ayam, there are another two elements which contribute to high capacity:

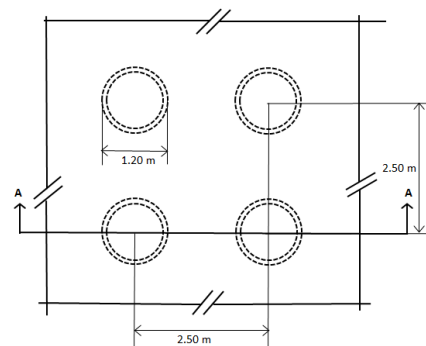

Fig. 1 Plan of Cakar Ayam system

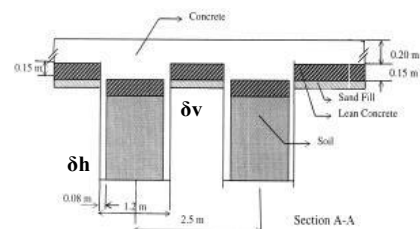

Fig. 2 Concrete pipes as stiffener of concrete slab

1. Numbers of Point and Friction capacity as well as capacity from raft Area.
2. Counter bending moment from the flexibility of slab and pipe

Regarding stiffness ratio, EI (E = Elastic Modulus, I = Moment of Inertia) [4] of slab to pipe concrete, there are two conditions to be considered :

- The stiffness ratio should be small enough to generate big passive resistance.
- The stiffness ratio should be big enough to contribute counter bending moment.

In this study, this ratio was thoroughly investigated.

The performances and variability in spacing between pipe, length of pipe and thickness of slab has been observed. There was a possibility to maximize bearing capacity which was not mentioned in the publication, by observing the slab to pipe stiffness ratio on particular soil.

In this study, simulation was done to the stiffness ratio of 0.02 to 1.15, bearing capacity, vertical and horizontal displacement were recorded for each pairs and consequently the result were plotted in the graph.

It is concluded that as the stiffness ratio increases, the bearing capacity also increases until maximum capacity at a certain stiffness ratio, and thereafter the bearing capacity will decrease. The increased of the slab thickness will reduce the vertical deformation which leads to reduce of lateral passive resistance and bearing capacity.

2. Finite Element Model

In this study, a three-dimensional finite element program, namely PLAXIS 3D FOUNDATION was used. This Finite element software is a special purpose three-dimensional computer program used to perform deformation and stability analyses for various type of geotechnical structures.

The Cakar Ayam Foundation was modeled three dimensionally (see Fig. 3), and the parameters used in this study were as follow:

Cakar Ayam system

- thickness of concrete slab varies from 0.08, 0.10, 0.12, 0.14 and 0.16 m
- length of concrete pipes = 2.50 m
- spacing between centre of concrete pipes = 2.50 m
- outer diameter of pipes vary from 0.80, 1.00, 1.20, 1.40 and 1.60 m
- concrete pipe thickness = 0.08 m
- elastic modulus of concrete pipes = 25,000 MPa
- elastic modulus of concrete slab = 30,000 MPa
- Poisson's ratio of concrete = 0.20

Soil

- $c = 10 \text{ kPa}$, $\phi = 20^\circ$, $\gamma = 16 \text{ kN/m}^3$
- elastic modulus of surrounding soil
 $E_{ref} = 3 \text{ MPa}$; $E_{oed} = 3 \text{ MPa}$; $E_{ur} = 8 \text{ MPa}$
- Poisson's ratio of soil = 0.3

Applied uniform loading = 20 kPa

3. Numerical Results

The deflection form of the whole elements is shown in Fig. 3 .

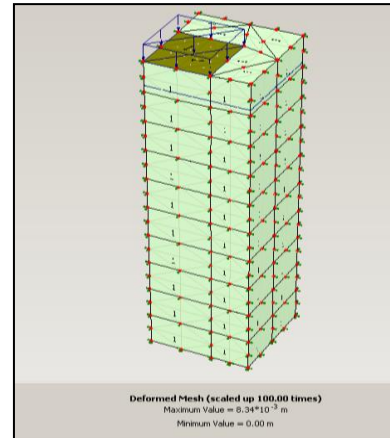

Fig. 3 Deflection form in Plaxis 3D Software

Based on the parameters mentioned above, stiffness ratio can then be calculated and the results are shown in Table 1.

Table 1 Stiffness Ratio ($\times 10^{-2}$) for different diameter of concrete pipe (individually) and thickness of concrete slab (2.5 m x 2.5 m).

Thickness of Concrete-Slab (m)	Diameter of Concrete Pipe (m)				
	0.80	1.00	1.20	1.40	1.60
0.08	14	7	4	2	2
0.10	28	14	8	5	3
0.12	49	23	13	8	5
0.14	77	37	21	13	8
0.16	115	55	31	19	12

After conducting the numerical modeling for Cakar Ayam system using the parameters mentioned above, the results are summarized in Table 2 as follow.

Table 2 Numerically obtained of vertical displacements (mm) for different diameter of concrete pipes and thickness of concrete slabs ($q = 20 \text{ kPa}$).

Thickness of Concrete Slab (m)	Diameter of Concrete Pipe (m)				
	0.80	1.00	1.20	1.40	1.60
0.08	9.11	9.38	11.14	13.07	15.39
0.10	9.21	9.51	11.19	13.16	15.45
0.12	9.30	9.58	11.23	13.20	15.47
0.14	9.35	9.62	11.28	13.21	15.45
0.16	9.41	9.66	11.33	13.24	15.43

Figure 4 shows the relationship between the stiffness ratios and the vertical displacements for varying thickness of concrete slabs and diameter of concrete pipes. It can be seen that the minimum vertical displacement is about 9 mm with the thickness of concrete slab of 0.08 m, in this vertical deformation. The capacity is considered to be maximum and can no longer

be reduced despite the stiffness ratio becomes increased. This is due to the increased in stiffness ratio will reduce passive resistance and concrete pipes are not functioning as stiffener of the concrete slab.

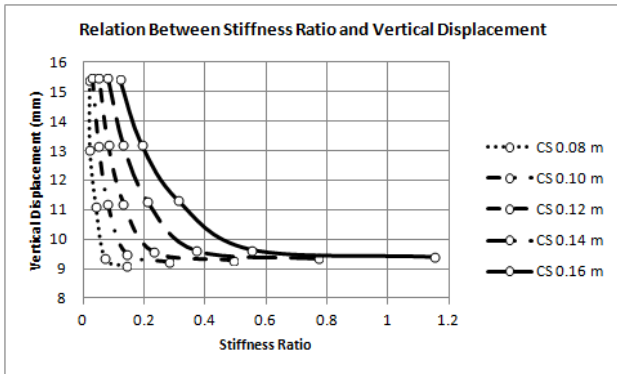

Fig. 4 Relationship between stiffness ratio and vertical displacement

The pipes serve as stiffeners to the concrete slab, by staying vertical due to the passive-soil pressure, it means that besides vertical displacement, there are some horizontal displacements of pipes. This significant displacement obtained from the numerical modeling is shown in Table 3. Position that need to be observed are in the middle of the slab and bottom of pipe as indicated by the node number in the Fig 5.

Table 3 Displacement of Nodes (m) on Concrete Slab (thickness = 0.08 m) and Pipe

Column Diameter	Displacement on Slab (NODE 10)	Displacement on Pipe (NODE 366)
0.80 m	$U_X = -4.684 \times 10^{-6}$ $U_Y = -7.103 \times 10^{-3}$ $U_Z = 4.684 \times 10^{-6}$	$U_X = -1.975 \times 10^{-6}$ $U_Y = -7.036 \times 10^{-3}$ $U_Z = 6.182 \times 10^{-6}$
1.00 m	$U_X = -1.341 \times 10^{-6}$ $U_Y = -7.820 \times 10^{-3}$ $U_Z = 1.341 \times 10^{-6}$	$U_X = -0.840 \times 10^{-6}$ $U_Y = -2.964 \times 10^{-3}$ $U_Z = 2.922 \times 10^{-6}$
1.20 m	$U_X = -6.323 \times 10^{-6}$ $U_Y = -8.764 \times 10^{-3}$ $U_Z = 6.323 \times 10^{-6}$	$U_X = -2.638 \times 10^{-6}$ $U_Y = -8.705 \times 10^{-3}$ $U_Z = 3.306 \times 10^{-6}$
1.40 m	$U_X = -1.179 \times 10^{-6}$ $U_Y = -7.461 \times 10^{-3}$ $U_Z = 1.179 \times 10^{-6}$	$U_X = -1.623 \times 10^{-6}$ $U_Y = -5.187 \times 10^{-3}$ $U_Z = 5.428 \times 10^{-6}$
1.60 m	$U_X = -8.204 \times 10^{-6}$ $U_Y = -11.429 \times 10^{-3}$ $U_Z = 8.204 \times 10^{-6}$	$U_X = -3.410 \times 10^{-6}$ $U_Y = -11.352 \times 10^{-3}$ $U_Z = 10.855 \times 10^{-6}$

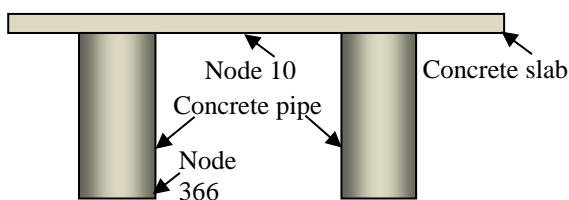

Fig. 5 Node number on slab and pipe

A relationship between stiffness ratio and horizontal displacement will be obtained when a regression line is drawn as shown in Fig. 6.

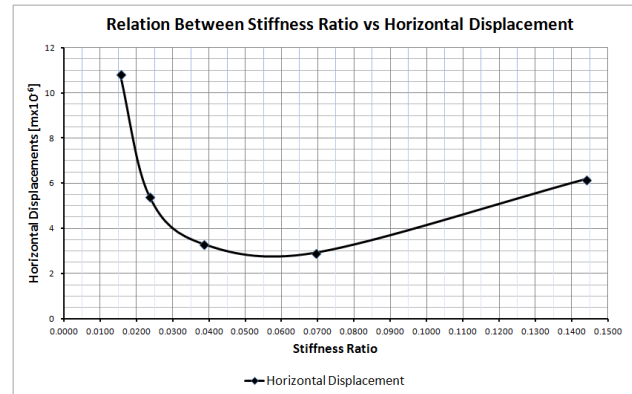

Fig. 6 Relationship between stiffness ratio and horizontal displacement

The curve in the Fig.6 explains that the pattern of horizontal deformation is typically similar with the non-linear lines in the Fig. 4, which support that the statement of maximum capacity located at certain stiffness ratio depends on the concrete slab thickness.

4. Discussion

The smallest slab thickness of 0.08 m exhibits smallest vertical displacement as can be seen in Fig. 4 and Table 3, more thinner slab thickness than 0.08 m is prohibited due to imposing more amount of reinforcement. Whereas for horizontal deflection, the theory of lateral earth pressure should be referred [5].

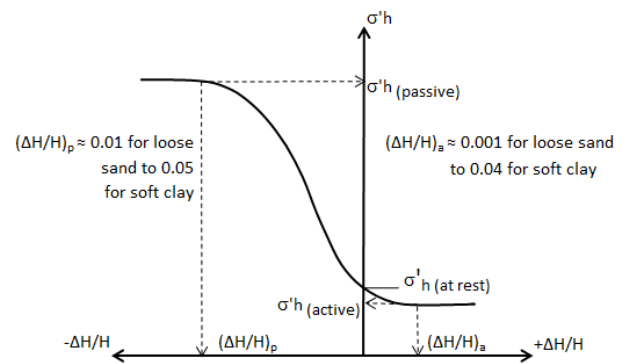

Fig. 7 Nature of variation of lateral earth pressure at a certain depth (after [4])

Maximum passive resistance can be achieved when horizontal displacement is $0.02 \times 2.50 \text{ m} = 0.05 \text{ m}$. While the maximum horizontal displacement obtained is $10.855 \times 10^{-6} \text{ m}$ (node 366, with diameter of concrete pipe is 1.60 m). The soil parameters used in this study was soft non granular soil, resulting in very small horizontal deformation on the bottom of pipe in the order of 10^{-6} m compared to 10^{-3} m as mentioned by Das [4]. This

indicates that the passive resistance doesn't reach maximum capacity.

For design example :

1. Let concrete slab with the thickness of 10 cm will be used, to find the most effective pipe diameter, the figure 4 gives Stiffness ratio of 0.18

From table 1, the appropriate pipe diameter is 0.9 m

2. Let concrete slab with the thickness of 16 cm will be used, to find the most effective pipe diameter, the figure 4 gives Stiffness ratio of 1.15.

From table 1, the appropriate pipe diameter is 0.8 m.

Conclusion and Recommendation

Conclusion

Based on the results of the parametric studies, it can be concluded that by increasing concrete slab thickness the CA capacity increases up to a certain thickness and CA capacity has achieved maximum value. The greater the slab thickness will results in reduced vertical displacement of the slab which in turn reduced the horizontal displacement of pipes (δh) and subsequently reduce the passive resistance. To obtain the proper proportion ratio of slab to pipe, Figure 4 and Table 2 can be used as reference.

Recommendation

To obtain more results, other parametric case study should be performed along with full scale test observations.

References

- [1] Daud, S., Junica, M.I., Sunaryo, M.E., Pertiwi, D. Kajian Dan Monitoring Hasil Uji Coba Sakala Penuh Teknologi Cakar Ayam Modifikasi. *Kolokium Puslitbang Jalan dan Jembatan TA 2009*, (2009).
- [2] Hardiyatmo, H. C. Analisis dan Perancangan Fondasi II. *Edisi Kedua, Gadjah Mada University Press*, (2011).
- [3] Tandjiria, V. Numerical Modelling of Chicken-Foot Foundation. *Dimensi Teknik Sipil Volume 1, no. 1 Maret*, (1999).
- [4] Badie, S. S. and Silva, P. Optimum Beam-To-Column Stiffness Ratio for Portal Frames. *Sturcture Magazine, March*, (2008).
- [5] Das, B.M. Principles of Foundation Engineering. *Seventh Edition, Cengage Learning*, (2007).